

Worcester Classic Spares

Unit K, Broomhall Business Centre, Broomhall Lane, Worcester, WR5 2NT

www.worcesterclassicspares.com

info@worcesterclassicspares.com



Mk 5

Parts List

01905
821569

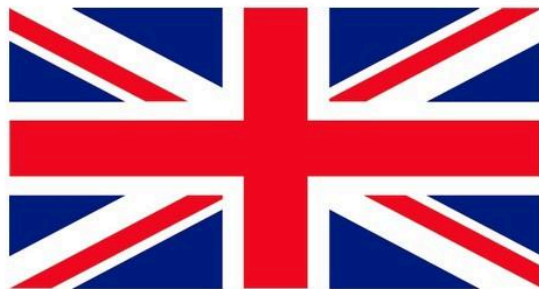

Open
Monday -Friday
1pm - 5pm

Dear Customer,

This price list outlines all the parts we can supply for the Jaguar Mk 5. These parts are mostly new reproduction. We try to hold as many parts in stock as possible, but some items are bought to order. If there is an item you require that is not listed, please let us know and we will make every effort to locate it for you and may be able to supply a used original part from our large selection.

Orders can be placed by WhatsApp, email or over the phone, when ordering please state our reference numbers (which appear on the far left of the page) and **provide details of your car – the make, year, chassis and engine numbers, body style and whether it is right or left hand drive**. If you are aware that the car has been modified or fitted with non-original parts please let us know as, unless notified, we will assume it is as original.

PRICES

The prices quoted are **per item** unless otherwise stated and are all in GBP. Whilst every effort will be made to adhere to the prices shown, we do reserve the right to make changes if necessary without prior notice. Any such change will be made known to the customer before sending out the order.

Please note the prices shown DO NOT include VAT - this will be added to orders for UK customers.

Payment can be made by debit or credit card (we are licensed to accept Visa and MasterCard) or by bank transfer. We also accept Paypal for orders of £100 or less.

SHIPPING/POSTAGE

Parts can be shipped to any part of the world using post or carriers on a door-to-door service - please see our terms and conditions. For small UK orders we used a tracked Royal Mail service. For larger UK orders, and all shipments going abroad, we use a variety of couriers using the company World Options.

Please note customers from the EU (and other countries) will need to pay customs/import duties when their parcel arrives in their own country. We are not involved in this - the courier should send the appropriate information and links via email.

WEBSITE

There are photos of most of the parts in this price list on our website, along with limited quantity items and Jaguar literature. We also have an expanding original parts section, the history of the company, photos of customer's cars from around the world and a restoration blog. New suggestions/contributions to our website are warmly welcomed. We are also on Facebook, see the **Mk 5 Community Group**.

STAFFING

WCS continues to be a family run business. Michael has now 'semi-retired' and works for the business on three days a week - Wednesday to Friday. I continue to be in the office from 1pm to 5pm each weekday (I have another job as a primary school teacher in the mornings!). If you have a technical enquiry that needs Michael's expertise, please ring the office and ask for a call back.

Anna Whitworth

CHROME FITTINGS

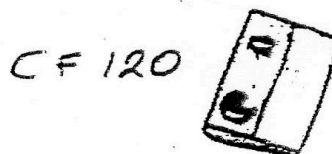
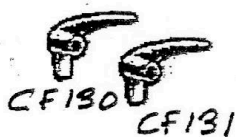
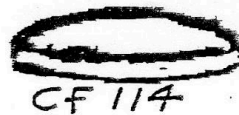
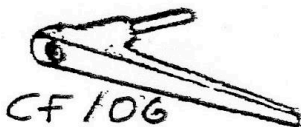
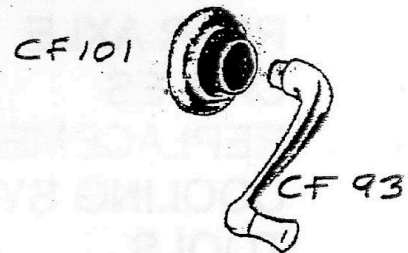
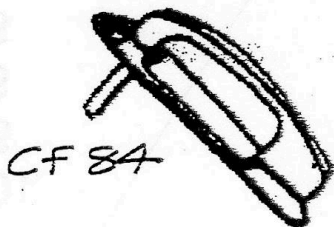
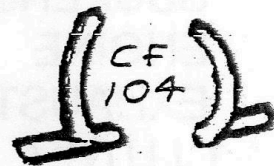
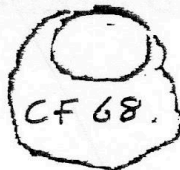
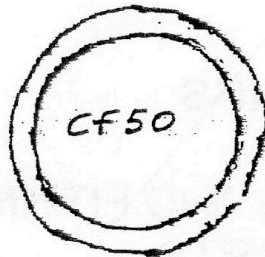
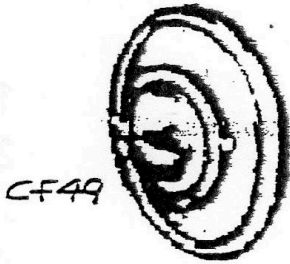
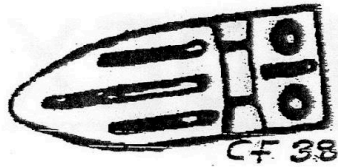
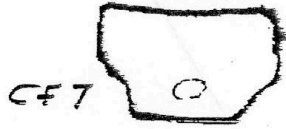

CHROME FITTINGS



| | | | |
|---------|-----------------|---|--------------------|
| CF. 7 | 5299/3462 | BOTTOM MOTIF - HEADLAMP RIM | £23.25 |
| CF. 27 | Bd.573 | HINGE for cubbybox lid on dashboard - unused original - fitted to <u>saloon cars only</u> , Chassis Nos. 520001 - 520282 and 527001 - 527073 (2.5L), 620001 - 621101 and 627001 - 627410 (3.5L) | £16.50 pair |
| CF. 37 | BD.2561 | HEADLAMP SPEAR | £28.50 |
| CF. 38 | BD.109 | HINGE for toolbox - 3 per car | £41.30 each |
| CF. 39 | BD.6206 | LEAPING JAGUAR MASCOT | £176.75 |
| CF. 49 | C.3243 | HUB CAP - chrome (original was part chrome and part paint) | £29.95 |
| CF. 50 | C.8385 | WHEEL TRIM - polished stainless steel (clips not supplied) | £45.00 |
| CF. 51 | C.3367 | HUB CAP BADGE with black background as original | £15.45 |
| CF. 59 | "572098" | CHROME SURROUND FOR BRAKE LIGHT | £19.50 |
| CF. 61 | | BONNET CENTRE HINGE LENGTH: 1365MM/53" | £92.20 |
| CF. 68 | Part of BD.2883 | ESCUTCHEON for petrol flap lock | £25.10 |
| CF. 72 | 5294 | SCREW securing headlamp rim | £2.80 |
| CF. 80 | BD.2188 | HANDLE OPERATING SUNROOF | £45.10 |
| CF. 84 | BD.603 | BOOT HANDLE AND ESCUTCHEON - lock barrel <u>not</u> included as standard, but available as a Special Order item for an additional charge. | £141 |
| CF. 88 | 2883 | CHROME SURROUND for horn push assembly | £51.75 |
| CF. 93 | BD.2233 | HANDLE FOR WINDOW REGULATORS - saloon and coupe | £58.60 |
| CF. 99 | BD.1978/1979 | BULKHEAD TRIM | £122.75 pair |
| CF. 101 | BD.552/1 | SPRING-LOADED ESCUTCHEON for window regulator - saloon and coupe | £19.95 |

| | | | |
|--------|--------------------|---|--------------|
| CF.104 | BD.2153/2154 | MOULDING at left and right side of spare wheel door - sold as pair - not available individually | £135.72 pair |
| CF.106 | BD.4057/4058 | EXTERIOR DOOR HANDLE - coupe - lock barrel and key <u>not</u> included - See BF.87 | £86.90 |
| CF.108 | BD.72 | LUGGAGE STRAP BRACKET/STAPLE - 4 per car | £41.50 |
| CF.113 | 252 | RADIATOR CAP (brass) + sealing ring - drilled to take leaping Jaguar mascot | £92.50 |
| CF.114 | 252 | RADIATOR CAP (brass) + sealing ring - not drilled for mascot | £92.50 |
| CF.117 | C.341 | DOME NUT on cylinder head - 3.5 7 per car | £8.05 each |
| CF.118 | C.580 | DOME NUT on cylinder head - 2.5L 12 per car | £8.05 each |
| CF.119 | C.412 | DOME NUT on rocker cover - 2.5/3.5L 3 per car | £5.30 each |
| CF.120 | BD.3991 | STRIKER PLATE for 1/4-light handle - Chassis Nos. 520631 – 520639, 520641 onwards and 527121 onwards (2.5L), 622291 onwards, 627727 onwards, 627702, 627703, 627706, 627717, 627722 and 627725 (3.5L) | £15.45 |
| CF.124 | BD.3991 | SCREW for original sidelight (where applicable) - normally fitted only to cars originally exported to Canada and USA | £4.55 pair |
| CF.126 | BD.6 | INTERIOR DOOR HANDLE - coupe only | £72.50 |
| CF.130 | BD.3981 | HANDLE locking front 1/4-light/no draught ventilator - left side (Chassis numbers as at CF.120 above) | £19.40 |
| CF.131 | BD.3982 | HANDLE locking front 1/4-light/no draught ventilator - right side (Chassis numbers as at CF.120 above) | £19.40 |
| CF.138 | 2312 | ROUND ESCUTCHEON - spare wheel compartment lock | £16.00 |
| CF.139 | BD.2551 | TEARDROP ESCUTCHEON - rear wheel spat | £15.50 |
| CF.140 | BD.2507/2508 | REAR QUARTER MOULDING - DHC | £228.25 pair |
| CF.141 | | KEY PIN through quarter light handle | £0.90 |
| CF.150 | 2310/1 | DOVE-TAIL STRIKER for door lock. DHC - state left or right | £90.10 |
| CF.151 | BD.1977 | DOOR PILLAR TRIM | £20.65 |
| CF.152 | | TOP MOTIF - HEADLAMP RIM | £23.25 |
| CF.160 | BD.2190 | TUBULAR SCREW – securing sunroof handle | £12.35 |
| CF.161 | BD.1971 BD.1972 | REAR QUARTER MOULDINGS - saloon | £99.50 pair |
| CF.163 | BD.2240 | EXTERIOR DOOR HANDLE - rear left | £117.20 |
| CF.164 | BD.2241 | EXTERIOR DOOR HANDLE - rear right | £117.20 |
| CF.165 | BD.2224 | EXTERIOR DOOR HANDLE - front left | £117.20 |
| CF.166 | BD.2225 | EXTERIOR DOOR HANDLE - front right | £117.20 |

BODY FITTINGS

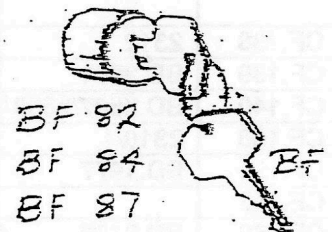
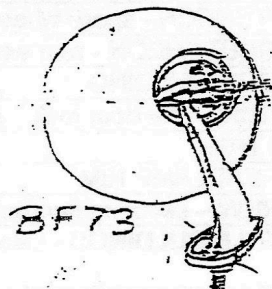
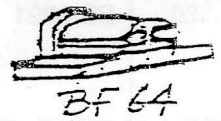
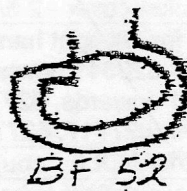
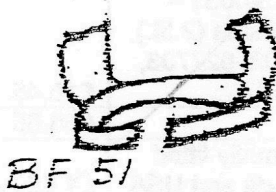
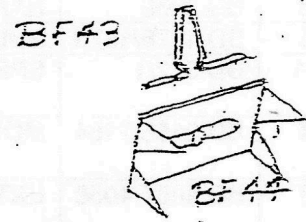
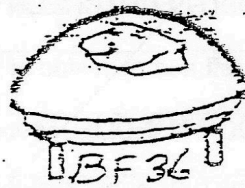
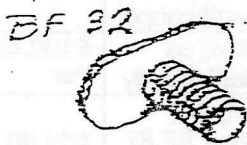
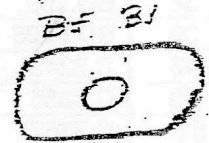
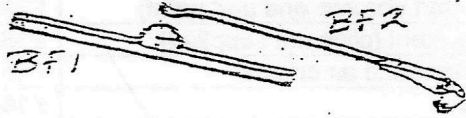

BODY FITTINGS

| | | | |
|--------|-------------------|---|---------------------------------|
| BF. 1 | 3562 | WINDSCREEN WIPER BLADE | £22.50 each |
| BF. 2 | 3556 | WINDSCREEN WIPER ARM | £33.50 each |
| BF. 3 | BD4076 | STUD FASTENER FOR HOOD STRAPS (metal thread) DHC only. 2 per car Also fits E-Type set 1, 1.5 & 2 DHC | £7.00 pair |
| BF. 6 | C.4691 | RED 'TELL-TALE' INDICATOR | £8.95 |
| BF. 7 | C.4098/2 | CLIP for 'tell-tale' indicator | £1.35 |
| BF. 29 | C.2670 | TRIANGULAR BRACKET for mounting windscreen wiper motor | £25.30 |
| BF. 30 | 1377 | BRACKET/HINGE FOR SUNVISORS DHC only | £165 each 2 per car |
| BF. 31 | BD.542/3 | OVAL WASHER - 1/4" hole (31 per car) | £0.45 |
| BF. 32 | BD.125 | SPECIAL T-BOLT and fixings securing chrome moulding at top of outer door panel. Saloon- 12 per car Coupe - 10 per car | £1.35 each |
| BF. 36 | | HORN PUSH New, reproduction plastic dome | £160 |
| BF. 43 | BD.3030 | CLIP securing interior trim to door - saloon | £0.40 |
| BF. 44 | BD.2702 | PLATE retaining above clip - saloon | £0.70 |
| BF. 51 | BD.8071 | SPRING CLIP securing petrol filler lock to filler door | £7.75 |
| BF. 60 | BD.212 BD.2248 | SPECIAL T-BOLT + nut and 2 washers - securing chrome mouldings to bonnet - 16 per car - and centre step-beads to front wings - 14 per car | £2.10 each |
| BF. 64 | 1524 | FRONT SUPPORT (brass) for bonnet hinge | £16.70 |
| BF. 65 | BD.1953 | REAR SUPPORT (brass) for bonnet hinge | £16.70 |
| BF. 68 | C.3727 | PETROL PIPE CLIP - as original | £5.80 each 8 per car |
| BF. 70 | C.3529 | BRAKE PIPE CLIP - as original | £5.80 each 10 per car |
| BF. 73 | C.9091/9092 | EXTERIOR/REAR VIEW MIRROR | £75 pair |
| BF. 74 | BD.813 | PIPING - wings to body (black plastic) Car set | £35.15 |
| BF. 76 | | FLAT WOVEN TAPE around radiator grille | £16.20 |
| BF. 81 | | KEYS - FNR series - all numbers from 1 - 50 - state number required | £9.90 |
| BF. 87 | BD. 1834 | LOCK BARREL (with pin & bolt) for exterior door handle (+keys) Coupe | £20.40 |
| BF.106 | | PETROL PUMP FITTING KIT (studs, grommets, washers & nuts) | £8.90 |
| BF.116 | C.2291 | GEAR LEVER KNOB | £20.40 |
| BF.117 | BD.2191 | BRACKET SECURING SUNROOF (Plated) | £25.10 pair |



RUBBER SEALS AND GASKETS

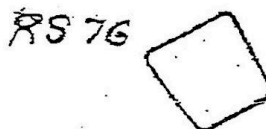
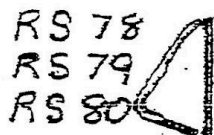
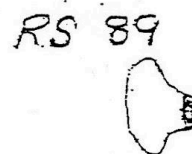
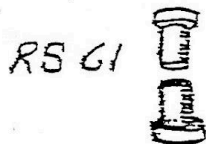
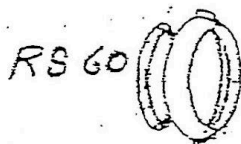
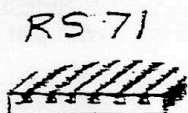
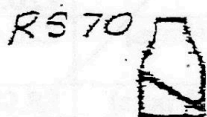
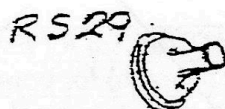
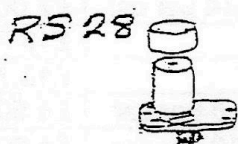
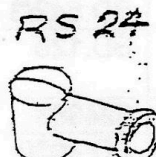
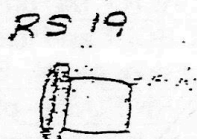
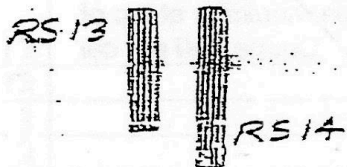

RUBBER SEALS & GASKETS



| | | | |
|--------|---------|---|-------------|
| RS. 7 | C2839 | SU PUMP RUBBER SLEEVE | £9.20 |
| RS. 8 | BD.1207 | WINDSCREEN SEAL | £19.25 |
| RS. 13 | 792 | RUBBER PEDAL PAD - brake and clutch | £10.65 pair |
| RS. 14 | C.3473 | RUBBER PEDAL PAD - accelerator | £8.50 |
| RS. 19 | 1048/A | FRONT JACK HOLE BUNG | £7.80 |
| RS. 22 | 552688 | HEADLAMP GASKET - lamp to car body | £5.30 |
| RS. 24 | C.4650 | BOOT for starter solenoid | £4.50 |
| RS. 28 | C.2659 | PAD for dipper switch | £12.50 |
| RS. 29 | C.3673 | DRAUGHT EXCLUDER - brake and clutch pedal | £7.80 each |
| RS. 50 | C.1788 | CONNECTING RING between intake pipe and air cleaner 2.5 & 3.5L | £18.10 |
| RS. 60 | | DUST SEAL for PF770 headlamp - between outer rim and light unit | £6.30 |
| RS. 61 | C.1915 | BUSH/BEARING for gear lever | £14.10 pair |
| RS. 62 | | REAR WHEEL SPAT SEAL | £9.80 pair |
| RS. 64 | BD2517 | RUBBER GROMMET in body sill for front and rear door check strap. Fitted to chassis numbers 520001 & subsequent, 620056 & subsequent (RHD) and also 527001 & subsequent and 627049 & subsequent (LHD), 4 per car | £57.75 each |

| | | | |
|--------|--------------|--|----------------|
| RS. 69 | 814 | STEERING COLUMN GROMMET | £19.70 |
| RS. 70 | 734181 | RUBBER GROMMET for windscreen wiper spindle | £8.50 each |
| RS. 71 | BD.2249 | RUBBER MAT in step bead frame (front wing running board chromes) | £54.45 car set |
| RS. 72 | BD.1997 | FILLER HOSE - tank to filler cap | £25.30 |
| RS. 73 | | SEALING RUBBER around door apertures - saloon Front door seal (280cm) - £19.52 per door Rear door seal (250cm) - £17.50 per door | £74.00 car set |
| RS. 74 | BD.2045/6 | SEALING RUBBER around door apertures - coupe | £23.70 car set |
| RS. 75 | | SEALING RUBBER around boot lid - all coupes & late saloons: chassis numbers 520413 onwards, 527074 onwards, 621520 onwards & 627429 onwards. | £16.50 |
| RS. 76 | BD.2065 | PETROL FLAP SEAL | £13.95 |
| RS. 78 | | FRONT ¼ -LIGHT SEAL - saloon This ¼ -light seals are the correct section of rubber but require some hand fitting - cut at pivot point, turn around, repeat at second pivot point, then glue ends together at joins. The vertical rubber seal (BD.46/4) at rear of ¼ -light is included) | £28 pair |
| RS. 79 | BD.3969/3970 | FRONT ¼ -LIGHT SEAL - coupe This ¼ -light seals are the correct section of rubber but require some hand fitting - cut at pivot point, turn around, repeat at second pivot point, then glue ends together at joins. The vertical rubber seal (BD.46/4) at rear of ¼ -light is included) | £28 pair |
| RS. 80 | | REAR ¼ -LIGHT SEAL – saloon This ¼ -light seals are the correct section of rubber but require some hand fitting - cut at pivot point, turn around, repeat at second pivot point, then glue ends together at joins. The vertical rubber seal (BD.46/4) at rear of ¼ -light is included) | £28 pair |
| RS. 82 | C.2979 | GROMMET for bulb-holder of rear lamp | £11.35 |
| RS. 83 | 571979 | GASKET for rear lamp - chrome rim to lamp | £15.45 |
| RS. 86 | 3204 | GROMMET in spark plug cable bracket | £17.50 |
| RS. 88 | 593 | BONNET REST RUBBER on scuttle | £16.75 |
| RS. 89 | 2263 | LANDAU BAR GROMMETS | £31.20 each |
| RS.103 | BD2159 | SEAL for spare wheel door channel on bottom of door (sealing around spare wheel door aperture - BD.2167/1 - not available) | £6.10 |
| RS.104 | BD2059 | FRONT SUNROOF SEAL | £10.65 |
| RS.105 | BD2058/1 | REAR SUNROOF SEAL | £5.95 |
| RS.114 | BD213/1 | RUBBER EXTRUSION in the chrome beading/strips on the boot floor and on the tool tray Car set | £19.70 |

ELECTRICAL PARTS

ELECTRICAL PARTS

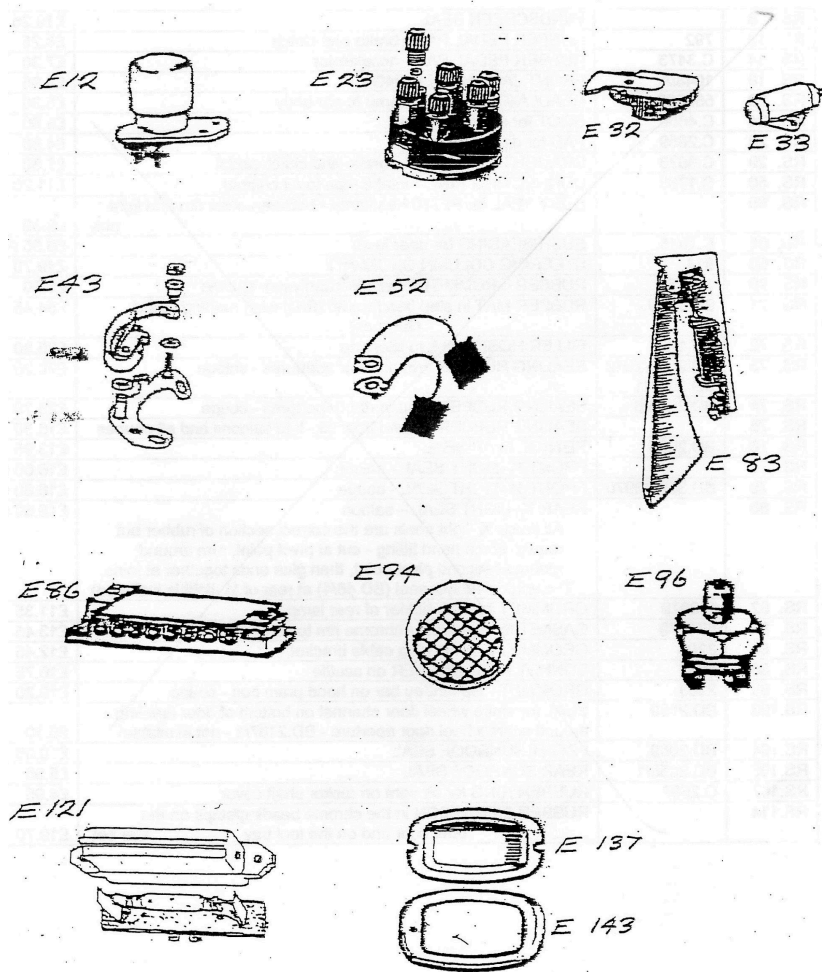

| | | | |
|-------|--------|--|--------------|
| E. 12 | C.2639 | DIP SWITCH - foot operated | £31.35 |
| E. 15 | C.4613 | SWITCH for map light/heater motor | £32.00 |
| E. 17 | | INTERIOR LIGHT LENSES | £78 pair |
| E. 23 | 2927 | DISTRIBUTOR CAP - (Lucas 407043) - the cables enter this cap vertically, not horizontally as original. Will fit distributors normally fitted with cap 415708 | £35.85 |
| E. 27 | C2558 | REAR NUMBER PLATE ILLUMINATION & REVERSE LIGHT - complete unit (including bulb) 2 per car | £142.50 each |
| E. 28 | 572694 | RIM & GLASS ASSEMBLY for rear number plate illumination and reverse light. | £50.75 |
| E. 29 | C2692 | STARTER SOLENOID | £29.50 |
| E. 31 | 2926 | ROTOR ARM | £7.35 |
| E. 33 | 2928 | CONDENSER | £11.95 |
| E. 43 | 2929 | CONTACT SET | £10.20 |
| E. 52 | 2804 | BRUSHES for starter motor Set of 2 | £9.60 |
| E. 53 | C2530 | VOLTAGE CONTROL BOX RF95/2 Original rebuilt item £50 discount available if old control box (in repairable condition) is sent in exchange. | £275 |
| E. 56 | 571997 | REAR BRAKE LIGHT LENSES with 3 heavy ribs. | £76 pair |

| | | | |
|---------|----------|---|--------------------------------|
| | | New reproduction, made from acrylic. | |
| E. 71 | "C4099" | FRONT SIDELIGHT The original bulb holder for this sidelight is within the sidelight pod on the front wing. This reproduction sidelight comes with a detachable bulb holder: the bulb holder is retained if the original is unusable, but can be removed if the original is still in good condition. This reproduction bulb holder is designed to take a twin filament bulb. Please note the lens is plastic, not glass. | £55.75 each |
| E. 83 | BD.1804 | TRAFFICATOR - professionally reconditioned Sold as a pair (for single units please ask) | £480 exchange £580 outright |
| E. 86 | C.2532 | CONNECTOR BLOCK (electrical wiring connector) | £26.00 |
| E. 94 | 57124 | RED REFLECTOR with chrome surround - 2" diameter, with bolt fixing. Not a Jaguar part but a "period addition" to comply with law | £25.45 pair |
| E. 96 | C.3901 | BRAKE LIGHT SWITCH - hydraulic - for LHD cars | £15.30 |
| E. 99 | C.2613 | BRAKE LIGHT SWITCH - mechanical - for RHD cars | £32.70 |
| E.121 | 319003 | LENS for map light | £69.50 |
| E.124/5 | | H.T. CABLE/WIRE for spark plugs and coil - one length of cable | £27.60 |
| E.127 | "C.2528" | IGNITION COIL - 12v coil with screw-down fittings (not the original Lucas sports coil) | £25.80 |
| E.136 | 513 | GROMMET in scuttle/bulkhead for water temperature/oil pressure pipes | £6.60 |
| E.137 | 532949 | LENS/WINDOW for boot/tool tray light | £15.25 |
| E.143 | 532948 | CHROME SURROUND for boot light above | £11.40 |
| E.169 | | SPARK PLUGS – Please state full engine number if 2.5/3.5L | £5.95 each |

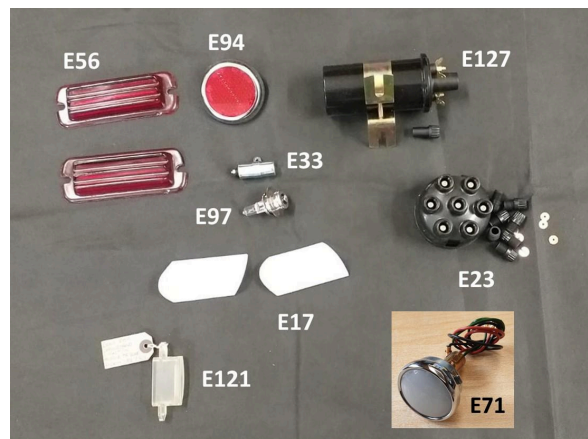

BRAKES

Early Braking System - Chassis Numbers as Follows

520001 - 520657 (2.5L saloon) 527001 - 527120
620001 - 622581 {3.5L saloon} 627001 - 627776
640001 - 640005 {3.5L coupe} 647001 - 647009
(Early system not fitted to 2.5L coupes)

Late Braking System - Chassis Numbers as Follows

520658 onwards {2.5L saloon} 527121 onwards
622582 onwards {3.5L saloon} 627777 onwards
640006 onwards {3.5L coupe} 647010 onwards
All 2.5L coupes

| | | | |
|------------|---------------------|--|--|
| BR. 16 | | LININGS AND RIVETS - front for <u>early</u> system as above; front and rear for <u>late</u> system as above | £68.75 axle set |
| BR. 17 | | REAR LININGS AND RIVETS for <u>early</u> system as above Axle set | £42.50 |
| BR. 21 | | MASTER CYLINDER - RHD | Exchange: £420 Outright: £520 |
| BR. 22 | | MASTER CYLINDER- LHD | Exchange: £420 Outright: £520 |
| BR. 39 | H.2736 | WHEEL CYLINDER - front left - early system - when available | £126.00 |
| BR. 40 | H.2737 | WHEEL CYLINDER - front right - early system - when available | £126.00 |
| BR. 45 | H.3152 | WHEEL CYLINDER (handbrake draw link not included) - rear left – late system - Refurbishment of customer's own cylinder only . Please see alternative below | £165 |
| BR. 46 | H.3153 | WHEEL CYLINDER (handbrake draw link not included - rear right-late system - reconditioned original | £165 |
| BR. 45/46A | "H.3152" & "H.3153" | ALTERNATIVE WHEEL CYLINDERS - rear left & right, late system - 1 inch cylinders with a 2 stud fixing (not as original but a suitable alternative). These could be fitted if the originals are not available, or for instance, if the old cylinders are not in a suitable state to be rebuilt. | £215 pair |
| BR. 54 | | REPAIR KIT - master cylinder Rubber seals only Complete kit | £15.10 £25.80 |
| BR. 67 | | REPAIR KIT - front cylinders for <u>late</u> system as above | £12.45 Axle set |
| BR. 68 | | REPAIR KIT - rear cylinders for <u>late</u> system as above - <u>please note</u> : with regard to late rear cylinders, there are two alternatives which both look identical on the outside. The most common version, which uses repair kit BR.68, has a piston that pushes the seal. The other version has a piston which is grooved and requires a seal in the form of a ring that fits into the groove. This version requires repair kit BR.141. | £16.10 Axle set |
| BR. 69 | | REPAIR KIT - front cylinders for <u>early</u> system as above | £14.95 Axle set |
| BR. 70 | | REPAIR KIT - rear cylinders for <u>early</u> system as above. This consists of the 4 rubber seals but does not include the rubber spreaders (reference H.1483) | £20.60 Axle set |
| BR. 98 | | FLEXIBLE BRAKE HOSE - front left or right | £23.90 |
| BR. 99 | H0221 | FLEXIBLE BRAKE HOSE - rear | £19.50 |
| BR.126 | C.4022 | HAND BRAKE CABLE ASSEMBLY at rear - <u>late</u> system as above | £56.00 |
| BR.127 | C.3378 | FRONT CABLE from hand brake to intermediate lever - RHD - | £49.75 |

| | | | |
|--------|----------|---|--------------------|
| | | Chassis Nos 520001 to 521365 and 540001 to 540010 (2.5L), 620001 to 624313 and 640001 to 640064 (3.5L) | |
| BR.128 | C.4799 | FRONT CABLE from hand brake to intermediate lever - LHD and RHD - Chassis Nos. 521366 onwards and 540011 onwards (2.5L), 624314 onwards and 640065 onwards (3.5L) | £49.90 |
| BR.135 | GB.40631 | RETURN SPRING for front brake shoes - <u>late</u> system as above | £13.30 |
| BR.141 | | REPAIR KIT - rear wheel cylinders (alternative to BR.68 - late braking system) | £18.65 Axle set |
| BR.153 | H.1278/H | HOSE between supply tank and copper pipe | £7.05 |
| BR.161 | | BRAKE LIGHT SWITCH – RHD only | £32.85 |

EXCHANGE CYLINDERS - please note that to qualify for an exchange, returned cylinders must be in a restorable condition and of the same specification as the replacement cylinder which we send. Cylinders with broken or missing studs do not qualify as an exchange as the studs cannot be replaced.

LATE System FRONT Cylinders

(Special Order Item)

These cylinders for the Mk 5 front late braking system are virtually impossible to obtain. There is a possibility that old cylinders could be professionally rebuilt but we have found that due to the brittle nature of this particular cylinder it is only a low percentage that are found to be suitable for rebuilding. Certainly if there is any damage to the studs these cannot be replaced and the cylinder is scrap.

There is an alternative cylinder that we can obtain but it does require a modification - the area on the cylinder that locates the end of the brake shoe needs to be machined to match the original. Also the hole centers are a slightly different dimension and require the back plate holes to be filed out by a small amount.

£272 for set of 4

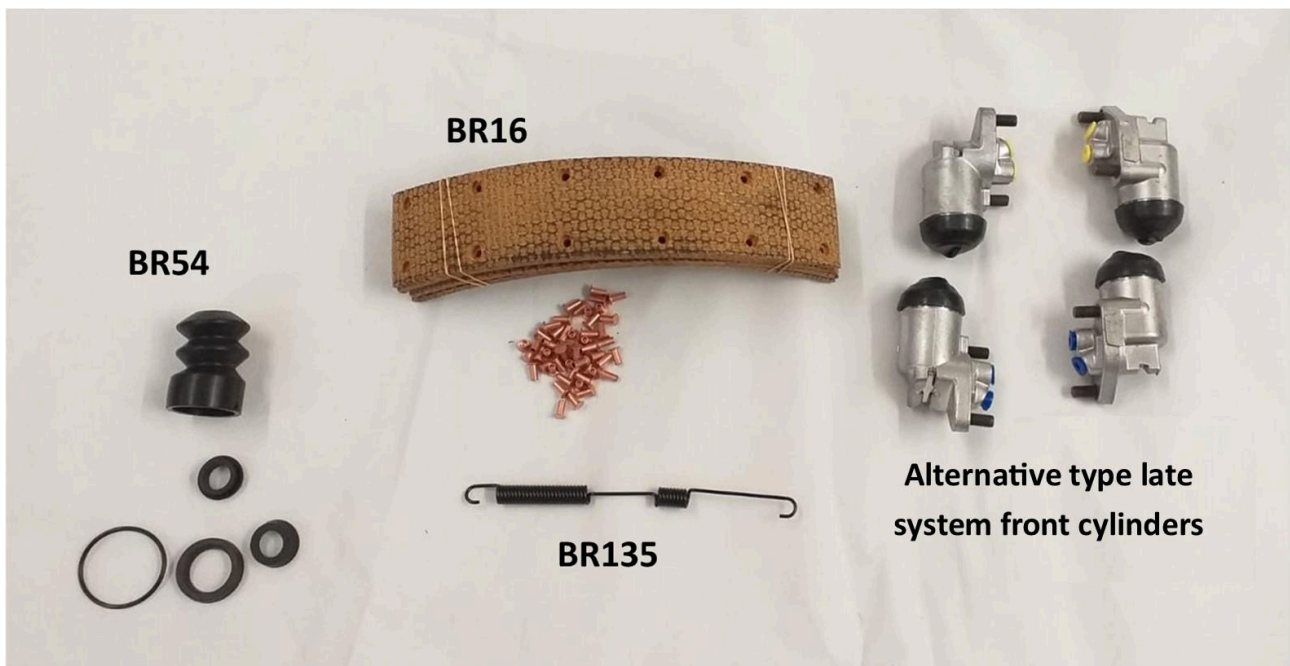

SUSPENSION AND STEERING

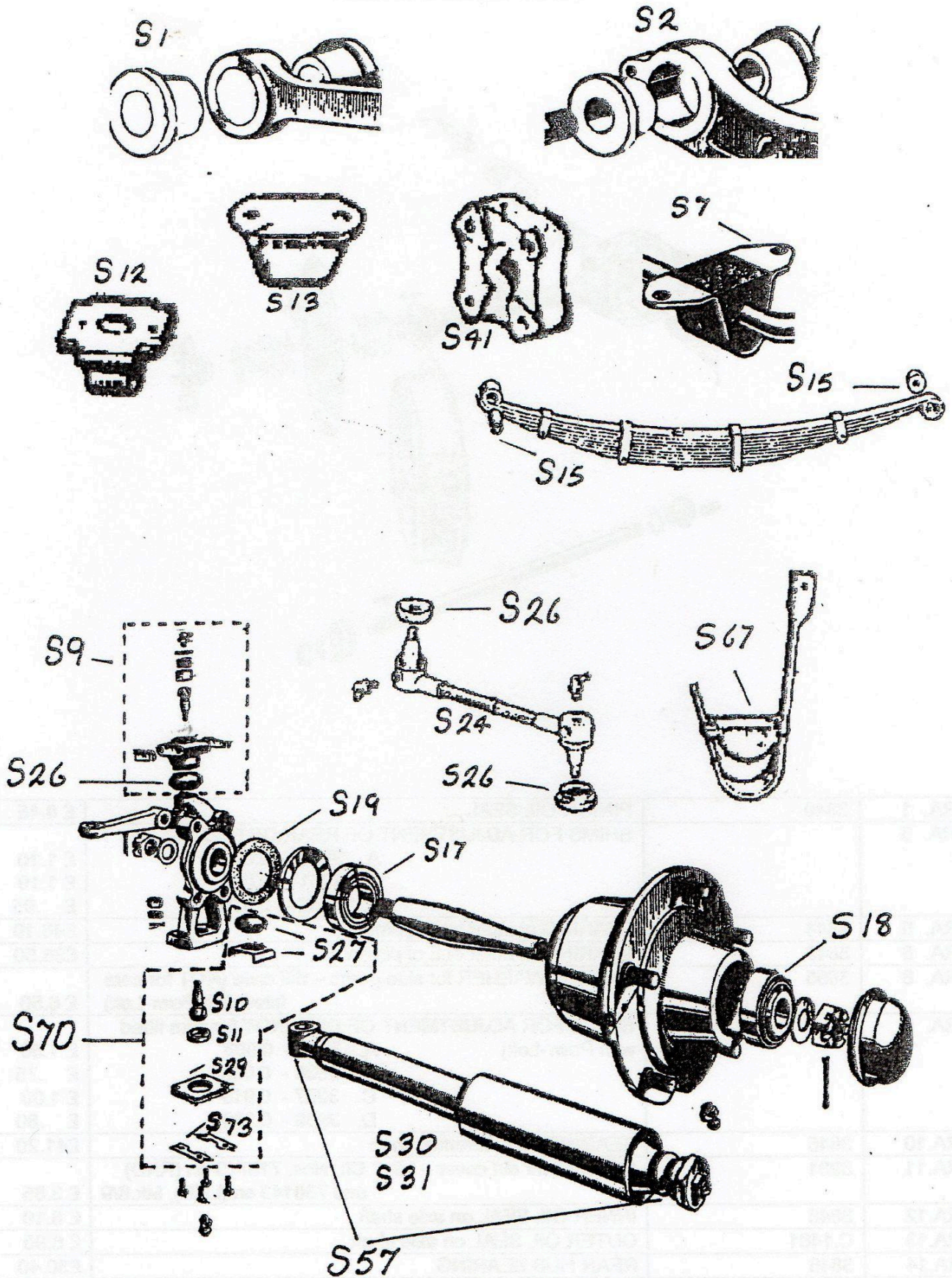

SUSPENSION & STEERING



| | | | |
|---------|--------|--|--------------------|
| S. 1 | C.3003 | TOP WISHBONE BUSH 8 per car | £5.40 each |
| S. 2 | C.3021 | BOTTOM WISHBONE BUSH 8 per car | £6.15 each |
| S. 7 | C.3054 | BRACKET over bearing - anti-roll bar link 2 per car | £18.20 |
| S. 9 | | UPPER BALL JOINT ASSEMBLY | £37.65 |
| S. 10 | C.3022 | LOWER SWIVEL PIN and nut (bottom ball joint) | £12.30 |
| S. 11 | C.3025 | SEAT/SOCKET supporting lower ball pin - see also S.70 - <u>Note:</u> the seat/socket supplied is a version that has an integral spigot/seating ring. If your car is presently fitted with the original bronze socket and a separate spigot (Jaguar No. C.3024), <u>do not attempt to refit the spigot</u> - discard it | £10.15 |
| S. 11/A | | SEAT/SOCKET supporting lower ball pin - original bronze type – comes complete with separate spigot. | £20.30 |
| S. 12 | C.3036 | FRONT BUMP STOP 2 per car | £12.85 each |
| S. 13 | C.3208 | REAR BUMP STOP 2 per car | £13.10 each |
| S. 15 | C.1219 | BUSH in front eye of rear road spring | 2 per car £5.30 |
| S. 16 | C.3334 | BUSH for shackle and rear eye of rear road spring 8 per car | £8.75 each |
| S. 17 | C.3011 | FRONT WHEEL INNER BEARING 2 per car | £27.90 each |
| S. 18 | C.3012 | FRONT WHEEL OUTER BEARING 2 per car | £26.85 each |
| S. 19 | C.615 | FELT GREASE RETAINER - front hub | £2.80 |

| | | | |
|-------|------------------|--|------------------|
| S. 20 | C.3062 C.3063 | TRACK ROD ENDS - Chassis Nos. 520001 to 521476, 527001 to 527190, 540001 - 540016 and 547001 - 547012 (2.5L), 620001 to 625201, 627001 to 628894, 640001 - 640147 and 647001 - 647534 (3.5L) | £69.80 pair |
| S. 23 | | TRACK ROD ASSEMBLY - fitted to 521477 on, 527191 on, 625202 on, 628895 on, 540017 on, 547013 on, 640148 on and 647535 on | £134.50 pair |
| S. 26 | C.3020 | RUBBER GAITER for track rod end/tie rod end and top ball joint. 4 per car. | £3.45 each |
| S. 27 | C.3029 | GAITER AND RETAINING PLATE for lower ball pin joint (made to ensure they <u>do</u> fit together) - see also S.70 | £10.90 |
| S. 29 | C.3026/1 | SHIM for bottom ball joint - see also S.70 | £2.50 |
| S. 50 | 27-9-4 | OIL SEAL in steering box at bottom of trunnion for rocker shaft | £5.35 |
| S. 52 | | PIN AND BUSH for centre track rod assemblies (see Item No. 65 on 'Plate CZ in Mk.5 parts book) This is a replacement pin and bush for 'End Assemblies' for track rods C.4135 and C.4136. It can also be used for the earlier track rod ends C.3493 and C.3494 - these had a threaded pin. The thread in the track rod ends has to be machined out to enable this later version of the pin and bush to be fitted. | £35.00 |
| S. 54 | C614 | COVER PLATE over grease retainer. | £12.75 |
| S. 55 | C.3035 | FRONT SHOCK ABSORBER and bushes (sold in pairs only) | £185 pair |
| S. 58 | | BUSH KIT for front shock absorber (1 kit per shock absorber) | £18.45 |
| S. 67 | 632 | BUFFER at bottom of check strap - rear axle | £17.60 |
| S. 70 | | LOWER BALL JOINT KIT - comprising lower swivel pin and nut, seat, gaiter, retaining plate, 2 lock plates, 2 shims | £39.50 |
| S. 73 | C.3028 | LOCK PLATE for lower ball joint (2 per side) - see also S.70 | £2.90 pair |
| S. 74 | | ANTI-ROLL BAR BUSH KIT (10 items - link bushes and bush/bearing on chassis) | £25.50 |
| S. 81 | C.3203 | STEERING IDLER SEAL | £3.70 |
| S. 93 | | OIL for lever arm shock absorber | £28.50 per litre |
| S. 98 | | BUSH for link arm - rear lever-arm shock absorber - considerable force is required to press these into the links. 4 per car | £8.70 each |

ENGINE

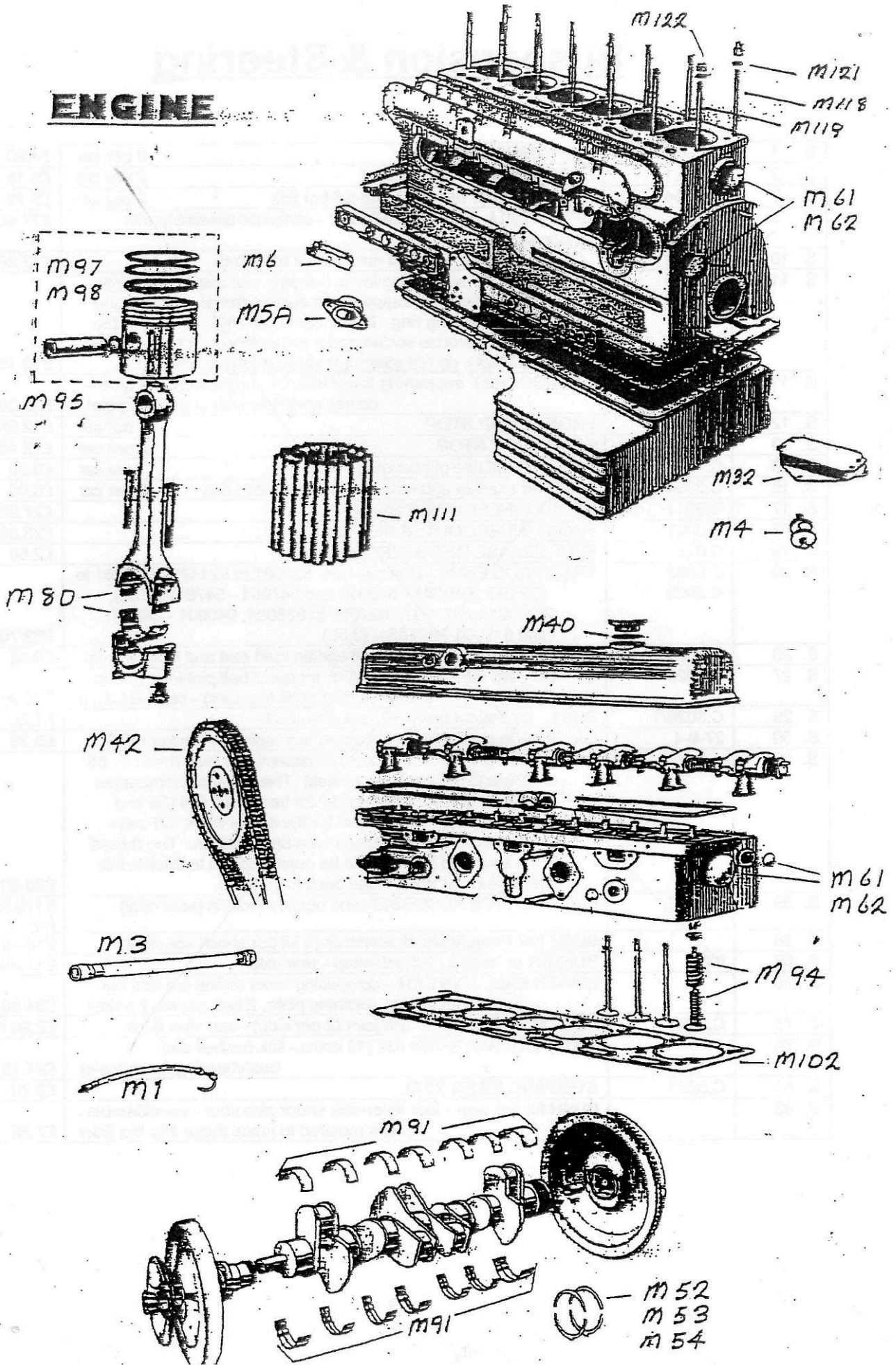

ENGINE

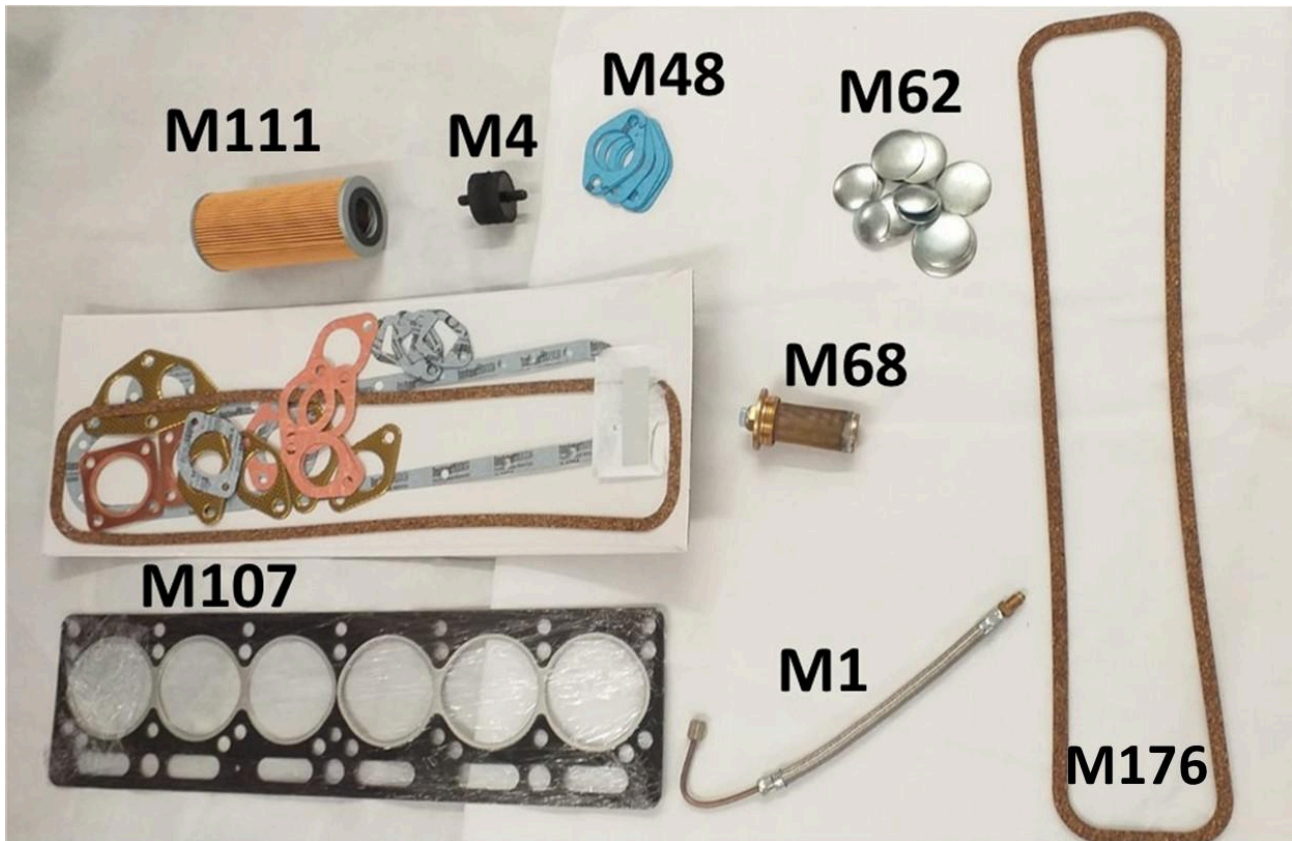

| | | | |
|-------|-------------|---|-------------|
| M. 1 | 1423A | FLEXIBLE OIL PIPE from oil cleaner to pressure gauge | £24.95 |
| M. 3 | C.3629 | FLEXIBLE FUEL LINE connecting feed pipe to carburettors | £29.75 |
| M. 4 | C.4304 | REAR ENGINE MOUNT - Chassis Nos. 521354 onwards, 527165 onwards, 540006 onwards, 547004 onwards (2.5L), 623892 onwards, 628121 onwards, 640034 onwards, 647131 onwards (3.5L), and also fitted to 24 individual, non-consecutive 3.5L chassis numbers prior to those listed above - check with your parts book. 2 per car | £11.75 each |
| M. 5A | C.4303 | FRONT ENGINE MOUNT - chassis numbers as at M.4 above 2 per car | £10.55 each |
| M. 6 | C.428 | FRONT ENGINE MOUNT - Chassis Nos. 520001 - 521353, 527001 - 527164, 540001 - 540005 and 547001 - 547003 (2.5L), 620001 - 623795, 627001 - 628080, 640001 - 640029 and 647001 - 647121 (3.5L), and also fitted to approx. 100 other 3.5L individual, non-consecutive chassis numbers, all later than those listed above - check with your parts book | £18.35 |
| M. 29 | 310 | RETURN SPRING for carburettor | £3.45 |
| M. 32 | C.478 | GEARBOX MOUNT - Chassis numbers as at M.6 above | £29.80 |
| M. 40 | C.419 | FIBRE GASKET on oil filler cap | £3.90 |
| M. 42 | C.1614 | DUAL TIMING CHAIN | £25.60 |
| M. 48 | C346 | INLET MANIFOLD GASKET SET between carburettor & head and air cleaner. 3.5L only | £27.50 set |
| M. 52 | C.559/C.462 | THRUST WASHERS - please state size: standard, +5, +10 | £35 set |
| M. 61 | | CORE PLUG SET - 2.5L | £18 |
| M. 62 | | CORE PLUG SET - 3.5L | £18 |
| M. 66 | C.540 | SPRING for timing chain tensioner | £19.25 |

| | | | |
|--------|--------------------|--|--------------------|
| | | Please note: this is an alternative type spring, not exactly as original | |
| M. 68 | C.990 | PETROL TANK FILTER/DRAIN PLUG | £59.25 |
| M. 71 | C.937 | CORK GASKET between sender unit and fuel tank | £1.05 |
| M. 72 | C1617 | GASKET/WASHER for petrol tank filter | £1.75 |
| M. 80 | SPECIAL ORDER | BIG END BEARINGS - 3.5L - for engines with <u>steel con rods</u> – standard, +10, +20, +30, +40, +60 thousandths of an inch – state oversize required | £85.50 car set |
| M. 80A | SPECIAL ORDER | BIG END BEARINGS - for engines with <u>alloy con rods</u> | Please ask |
| M. 91 | SPECIAL ORDER | MAIN BEARINGS for 2.5 & 3.5L Standard, +10, +20, +30, +60 State oversize required | £305 car set |
| M. 93 | 2x C411 1x C638 | GASKET SET FOR WATER UPTAKE MANIFOLD - 2.5L | £15.50 set |
| M. 95 | C2439 | SMALL END BUSHES - 3.5L - for engines with steel con rods - set of 6 | £46.50 set |
| M. 96 | 3x C411 | GASKET SET FOR WATER UPTAKE MANIFOLD - 3.5L | £14.75 set |
| M. 97 | C.2562 | PISTONS, rings and gudgeon pins - 3.5L - standard, +20, +30, +40, +60 thousandths of an inch oversize - state oversize required (+10 not available) - obtained to order only | £680 car set |
| M. 98 | C.2565 | PISTONS, rings and gudgeon pins - 2.5L - standard, (+10 not available) +20, +30, +40, +60 thousandths of an inch oversize - state oversize required - obtained to order only | £680 car set |
| M. 99 | C328, C4201 | VALVE GUIDES - inlet and exhaust | £28.50 each |
| M.100 | FW105E | COPPER WASHER - 5/16" | £0.50 each |
| M.101 | C.531 | FAN BELT | £30.40 |
| M.102 | C.337 | CYLINDER HEAD GASKET - 3.5L COMPOSITE | £230 |
| M.103 | | CYLINDER HEAD GASKET - 2.5L COMPOSITE | £230 |
| M.106 | | CYLINDER HEAD GASKET SET - 2.5L with composite head gasket | £335.00 |
| M.107 | | CYLINDER HEAD GASKET SET - 3.5L with composite head gasket | £335.00 |
| M.109 | | CONVERSION GASKET SET - 2.5L & 3.5L | £95 |
| M.111 | | OIL FILTER | £17.25 |
| M.118 | C.339 | STUD securing cylinder head - 3.5L only 6 per car | £15.20 each |
| M.119 | C.340 | STUD securing cylinder head - 3.5L only 8 per car | £15.20 each |
| M.121 | C.789 | WASHER on cylinder head studs 14 per car, supplied as a set of 7 | £9.20 per set of 7 |
| M.122 | C.2138 | CAP NUT for cylinder head studs (cap not supplied) 7 per car | £3.10 each |
| M.128 | FN 107/L | BRASS END TERMINAL for spark plug lead - 6 per car | £1.95 each |
| M.144 | C380 | TIMING COVER GASKET 2.5/3.5L | £18.50 |
| M.145 | | LOCK NUT securing valve clearance adjustment screw - 12 per car | £2.15 each |
| M.169 | C.385 | SUMP/OIL PAN GASKET | £29 |
| M.174 | | EXHAUST VALVES - 3.5L, sold as set of 6 | £248 set |
| M.175 | | INLET VALVES - 3.5L, sold as a set of 6 | £248 set |
| M.176 | C.457 | ROCKER BOX GASKET - 3.5L extra thick (4mm) | £23.50 |
| M.177 | C.810 | ROCKER BOX GASKET - 2.5L extra thick (4mm) | £23.50 |
| M.179A | | SMALL END BUSHES - 2.5L only (set of 6) 1938-1951 | £97.50 |
| M.180 | | EXHAUST VALVES 2.5L, sold as a set of 6 | £228 set |
| M.181 | | INLET VALVES 2.5L, sold as a set of 6 | £228 set |
| M.182 | | OIL PUMP - reconditioned original when available. £50 discount for serviceable exchange. | £175 |
| M.185 | 36411 C382 | LOCKING PLATE ON TIMING CHAIN WHEEL ON CAMSHAFT | £7.75 |

| | | | |
|-------|------------|---------------------------------------|--------|
| | | 2.5L & 3.5L | |
| M.186 | 50178 C545 | RING LOCKING STARTER JAW 3.5L only | £10.75 |

EXHAUST

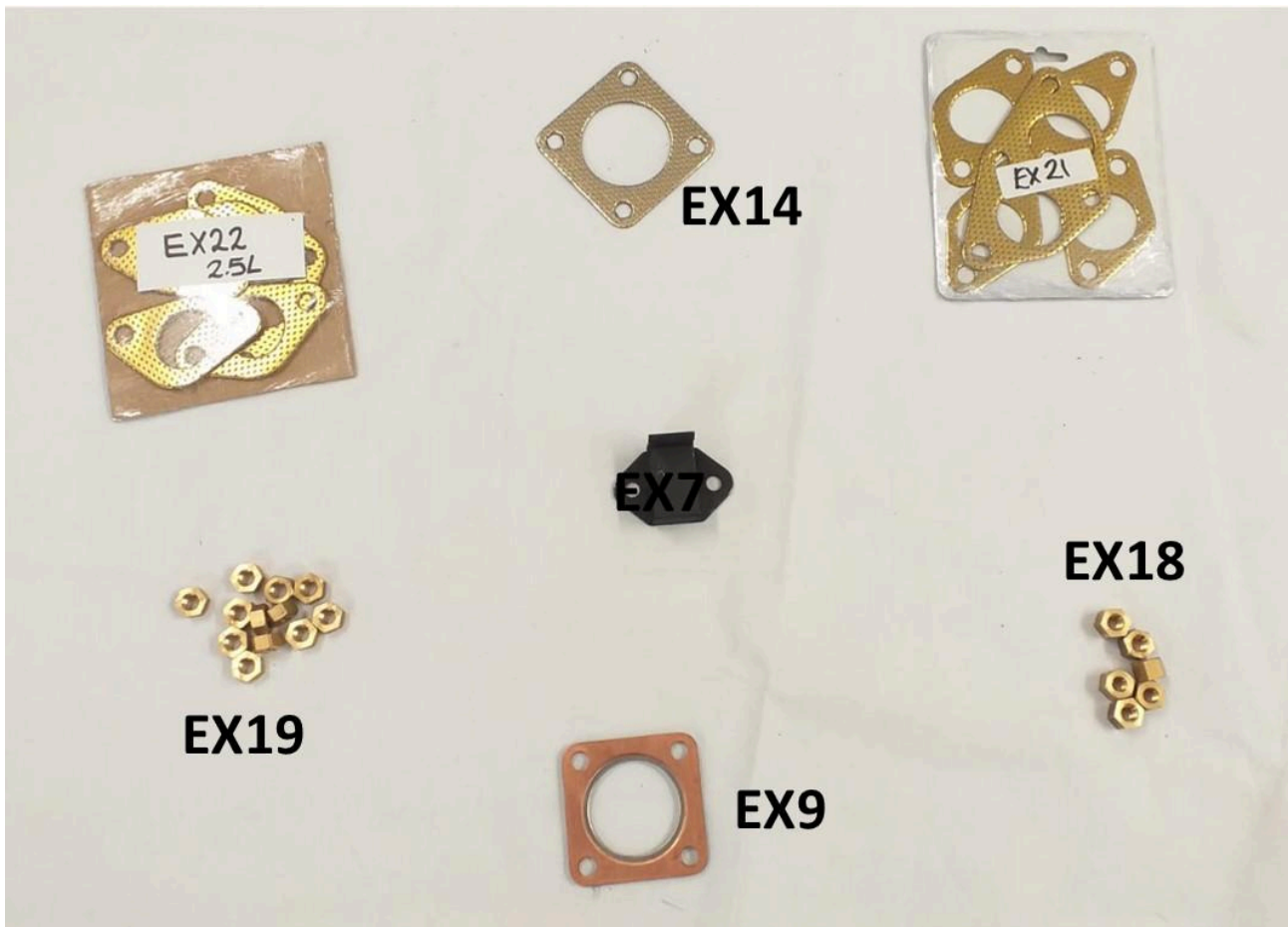

| | | | | |
|--------|---------|---|------------|---------------------|
| EX. 7 | 1363 | RUBBER MOUNT - right-angled - for silencers | 2 per car | £4.30 |
| EX. 9 | C.495 | GASKET between exhaust manifold and downpipe | | £12.55pair |
| EX. 14 | C.3584 | GASKET between downpipe and intermediate pipe | | £5.85 |
| EX. 16 | | EXHAUST MANIFOLD STUDS & NUTS for connecting the manifold to the downpipe. 3/8" UNF x 7/16" These are stepped studs to be used after a new thread has been tapped, following drilling out the remains of the old ones. Sold in packs of 4 studs & 4 nuts. 2.5/3.5L - 2 packs per car | | £21.50 pack of 4 |
| EX. 18 | FN.106K | BRASS NUT securing exhaust pipes to exhaust manifold | 8 per car | £12.45 set |
| EX. 19 | FN.106 | BRASS NUT securing exhaust manifold to cylinder head. | 12 per car | £16.15 set |
| EX. 21 | | Exhaust manifold gasket set – 3.5L | | £35.50 |
| EX. 22 | | Exhaust manifold gasket set - 2.5L | | £35.50 |

CLUTCH

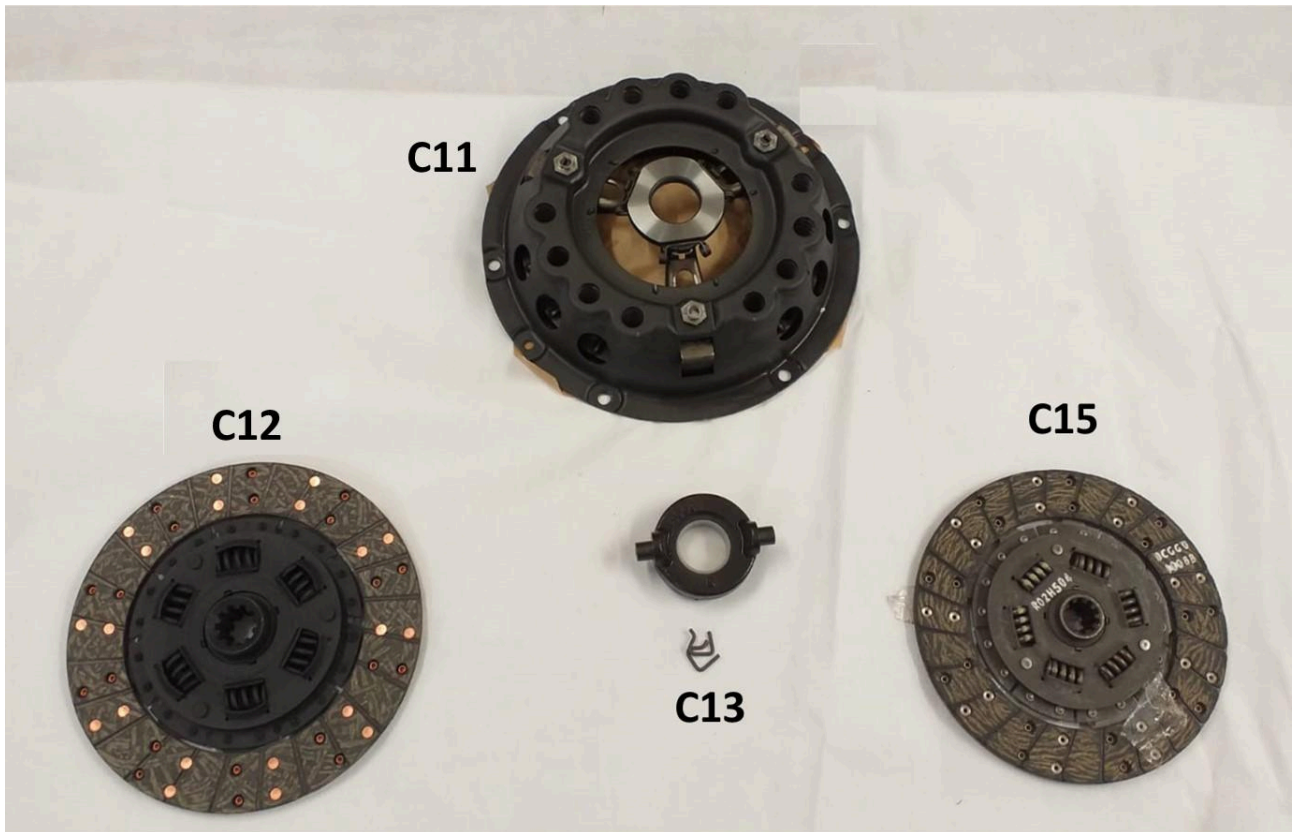

(All surcharges are refundable upon receipt of the old unit)

| | | | | |
|-------|--|------------------------------------|-----------------------|-------------|
| C. 11 | | CLUTCH PRESSURE PLATE - 10" - 3.5L | EXCHANGE SURCHARGE | £125 £80 |
| C. 12 | | FRICION PLATE - 10" | EXCHANGE SURCHARGE | £62 £50 |
| C. 13 | | RELEASE BEARING | | £35 |
| C. 14 | | CLUTCH PRESSURE PLATE - 9" - 2.5L | EXCHANGE SURCHARGE | £125 £80 |
| C. 15 | | FRICION PLATE - 9" | EXCHANGE SURCHARGE | £62 £50 |

GEARBOX

| | | | | |
|-------|--------|---|------------------|------------|
| G. 2 | C.1850 | NEEDLE ROLLER in 2nd and 3rd speed gears | Set of 82 | £44.50 set |
| G. 3 | C.918 | NEEDLE ROLLER | Set of 58 | £37.40 set |
| G. 6 | C.912 | OIL SEAL at front end of gearbox | | £5.50 |
| G. 7 | C.859 | OIL SEAL at rear end of gearbox | | £6.50 |
| G. 27 | C.924 | BEARING in gearbox extension (SH10 on, JH10 on) | | £50.25 |
| G. 29 | C.883 | ROLLER BEARING for main shaft | | £100.85 |
| G. 30 | | GASKET SET - SH and JH gearboxes | | £12.90 |
| G. 31 | C.1845 | BEARING for main shaft, fitted to SH10-SH6148 gearboxes | | £42.85 |
| G. 32 | C.1838 | BEARING - constant pinion shaft | | £34.80 |

TRANSMISSION

| | | | | |
|-------|------------|--|--|--------------|
| TR. 1 | 94/GB.1598 | GREASE NIPPLE for universal joint - propshaft | | £2.00 |
| TR. 2 | K.5/L/4 | UNIVERSAL JOINT/JOURNAL ASSEMBLY with grease nipple. Genuine Hardy Spicer 3 per car | | £25.40 each |
| TR. 3 | 94/GB.2147 | BEARING for propshaft center mount | | £42.80 |
| TR. 4 | C.3930 | INSULATOR in mounting plate flanges for propshaft 2 per car | | £17.50, each |
| TR. 6 | K.2/2/239 | FLANGE YOKE on front propshaft assembly and at each end of rear propshaft assembly | | £31.90 |
| TR. 7 | K.2/3/68 | SLEEVE YOKE ASSEMBLY on sliding end of rear propshaft assy | | £38.35 |

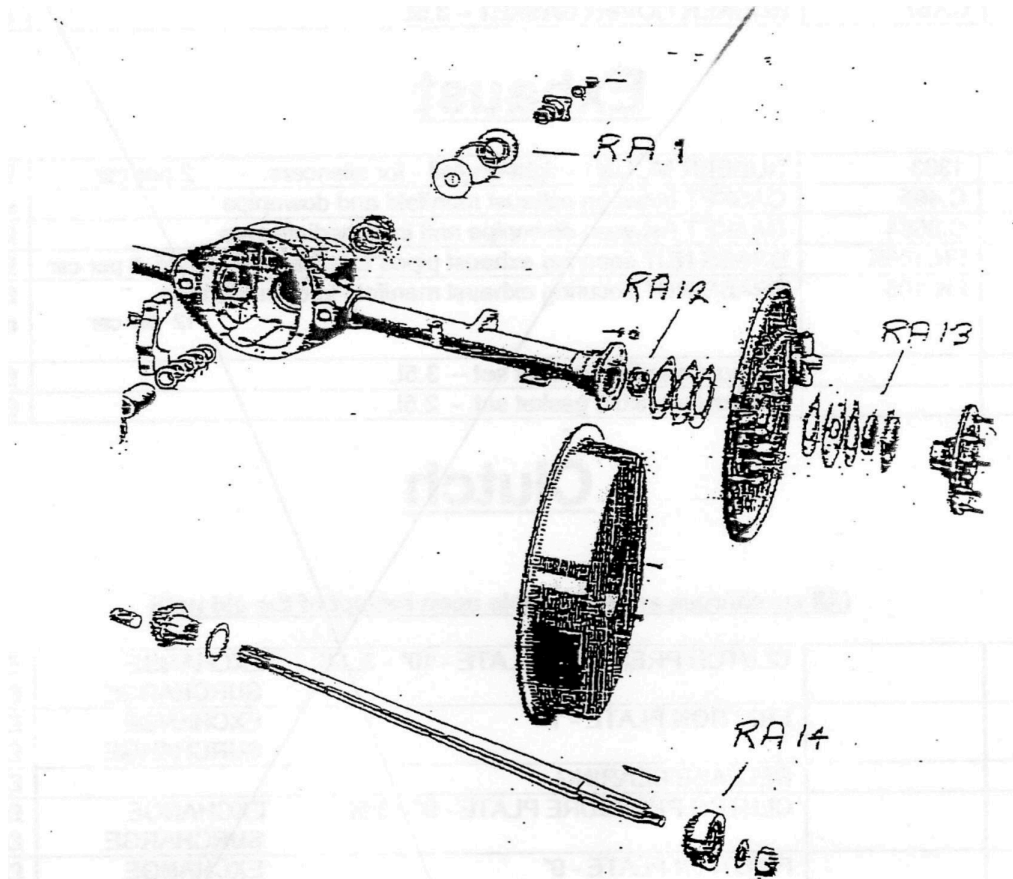

REAR AXLE

SALISBURY AXLE

| | | | |
|--------|-----------------|--|----------------|
| RA. 1 | 2HA-019 | PINION OIL SEAL | £ 8.85 |
| RA. 2 | 2HA-020 | GASKET for pinion oil seal | £1.78 |
| RA. 5 | 2HA-023 | BEARING at inner end of pinion | £48.20 |
| RA. 6 | 2HA-022 | BEARING at outer end of pinion | £38.15 |
| RA. 8 | 2HA-038 | THRUST WASHER for side gears | £16.50 pair |
| RA. 10 | 2HA-024 | BEARING on differential case (2 per car) | £43.05 each |
| RA. 12 | 2HA-027 3848 | INNER OIL SEAL on axle shaft (2 per car) | £6.40 each |
| RA. 13 | 2HA-032 | OUTER OIL SEAL on axle shaft (2 per car) | £7.25 each |
| RA. 14 | 3846 | REAR HUB BEARING (2 per car) | £31.70 each |
| RA. 18 | C3041 | WHEEL NUTS - front & rear | 3.50 each |
| RA. 26 | C3040 C13365 | WHEEL STUD - front & rear 5 per wheel | £11.75 each |

ENV AXLE

| | | | |
|--------|-----------------|--|----------------|
| RA. 17 | 801 | OIL SEAL - rear hub | £7.70 |
| RA. 18 | C3041 | WHEEL NUTS - front & rear | £3.50 each |
| RA. 19 | A-254-12 | OIL SEAL - axle shaft | £10.60 |
| RA. 20 | H-105-22 | PINION OIL SEAL | £36.80 |
| RA. 21 | A-254-63 | HUB BEARING | £39.50 each |
| RA. 22 | A-254-63 | BEARING each side of differential gear | £39.50 each |
| RA. 23 | H-108-41 | FRONT PINION BEARING | £29.36 |
| RA. 24 | H-108-40 | REAR PINION BEARING | £42.50 |
| RA. 26 | C3040 C13365 | WHEEL STUD - front & rear 5 per wheel | £11.75 each |

CABLES

| | | | |
|--------|--------|--------------------------------------|--------|
| CB. 10 | C.1434 | SPEEDOMETER CABLE (66.5 inches long) | £34.80 |
| CB. 15 | C.2874 | REV COUNTER CABLE - 2.5L | £38.50 |
| CB. 16 | C.2856 | REV COUNTER CABLE - 3.5L | £38.50 |

REPLACEMENT PANELS

| | | | |
|-------|--------|---|---------|
| P. 45 | 52043A | FRONT SIDELIGHT HOUSING - to be welded onto front wing – metal pod/housing only | £147.86 |
| P. 46 | | FRONT VALANCE/PLINTH PLATE ASSEMBLY above front bumper | £125.40 |
| P. 47 | | REAR VALANCE/PLINTH PLATE ASSEMBLY above rear bumper | £125.40 |

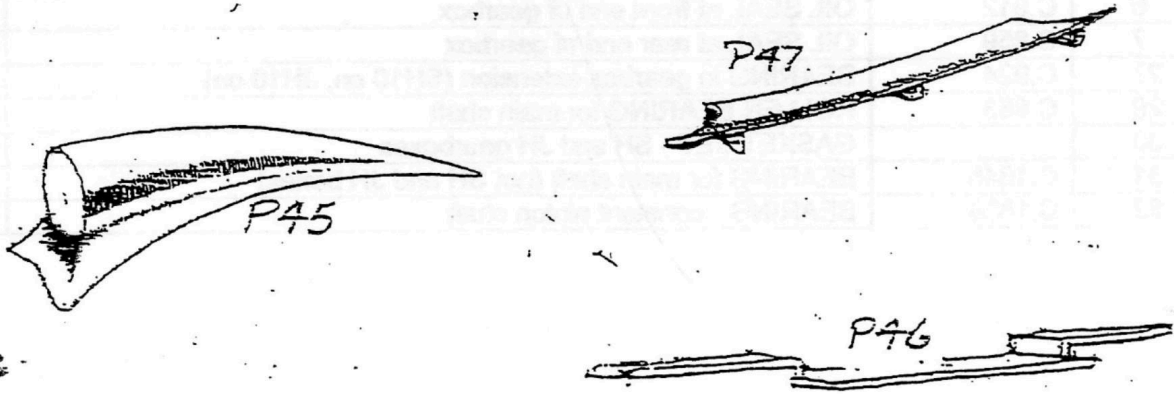

COOLING SYSTEM

| | | | |
|------|-----------|--|------------|
| CS5 | C2819 | BY-PASS HOSE for 3.5L (previously CS41) | £15.20 |
| CS6 | C705 | WATER PUMP BEARING - front | £15.25 |
| CS7 | C706 | WATER PUMP BEARING - rear | £15.95 |
| CS18 | C714 | RUBBER SEALING RING for filler cap (previously CS38) | £4.40 |
| CS19 | C384 | CARBON GLAND BUSH for water pump - 1.5L, 2.5L & 3.5L (previously CS46) | £39.50 |
| CS20 | C1506 | BOLT AND TWO COPPER WASHERS securing banjo on water pump- all 2.5 only | £9.87 |
| CS31 | | HEATER HOSE KIT | £43.90 |
| CS32 | C3498 | TOP RADIATOR HOSE | £21.50 |
| CS33 | C3499 | BOTTOM HOSE | £21.95 |
| CS34 | C2821 | BY-PASS HOSE for Mk 5 2.5L only | £15.80 |
| CS35 | C388 C389 | FELT WASHERS for water pump 2.5 & 3.5L | £8.50 pair |
| CS39 | C2810 | BACK PLATE for water pump (new reproduction) | £165 |

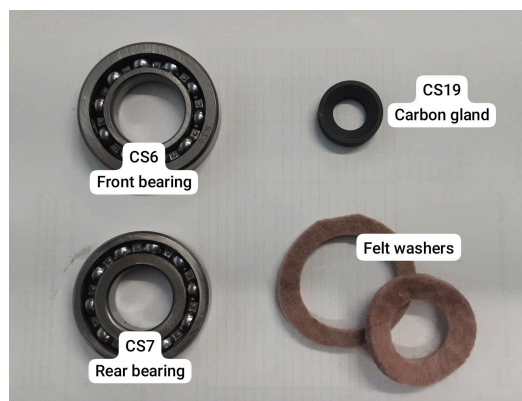

TOOLS

| | | | |
|-------|---------------|--|-------------|
| T. 1 | pt of C997 | HANDLE FOR TYRE PUMP as fitted to Mk 4/5/XK120 | £14.50 |
| T. 2 | C.993 | EXTRACTOR FOR TYRE VALVE | £9.00 |
| T. 4 | C.994 | ADJUSTABLE SPANNER - original second-hand | £16.05 |
| T. 5 | C2954 | JACK RATCHET HANDLE (used original) | £28.00 |
| T. 7 | C.991 | OIL GUN/GREASE GUN - original second-hand | £53.80 |
| T. 11 | | WOODEN HANDLED SCREWDRIVER (used) | £13.75 |
| T. 12 | C31 | BOX SPANNER - new reproduction 3/16 x 1/4 | £35 |
| T. 13 | C32 | BOX SPANNER - new reproduction 5/16 x 3/8 | £35 |
| T. 14 | C33 | BOX SPANNER - new reproduction 7/16 x 1/2 | £35 |
| T. 17 | C31, C32, C33 | BOX SPANNERS - set of 3 which 'nest' (fit inside each other). | £105 set |
| T. 18 | C179 | SINGLE ENDED BOX SPANNER for spark plugs | £35 |
| T. 19 | C2585 | BOX SPANNER for torsion bar adjustment | £38.50 |
| T. 24 | C.13620 | DUNLOP BLEED TUBE TIN - exact replica with lid screen-printed in same way as original. Same size as Girling tin originally fitted to Mk.V. (Bleed tube not supplied on instruction of Dunlop.) | £19 |
| T. 26 | C.996 | PLIERS - original second-hand | £11.20 |
| T. 28 | C.34 | SHORT TOMMY-BAR | £12.55 |
| T. 36 | C.1002 | SCREWDRIVER for distributor for setting points. (Remade with permission of Lucas and approved by them.) | £9.95 |
| T. 41 | C1001 | TYRE LEVERS - original, used | £19.50 pair |
| T. 42 | C.30 | LONG TOMMY-BAR | £17.25 |



Terms & Conditions

USED PARTS

Although as good a description as possible will be given of the second-hand items, everyone's idea of condition varies. If there is a known or obvious fault with the part, then the prospective customer will be made aware of it. However, if we supply any second-hand part, be it a single item or a mechanical or mechanised part, or any item that consists of component parts, which is later found to be faulty, unfortunately we would be unable to offer a refund or a replacement part. By the very essence of their nature, second-hand parts are always an unknown quantity, and no guarantee can be given to their condition. It is at the buyer's risk that such items are purchased.

DISCOUNTS

We regret that we cannot give discounts, however large the order or regular the custom. We feel it is fairer to price the parts as competitively as possible to give a fair deal to all our customers, some of whom prefer to order all the parts they need at one time, whilst others prefer to order over a period of time.

LIABILITY

Liability extends only to replacement free of charge, or a refund, in respect of items incorrectly supplied or found to be faulty (not including second-hand items), and notification must be received within 14 days of despatch of goods, so please check your order as soon as you receive it. We regret we cannot give refunds on parts correctly supplied but no longer required.

The return postage on any item which is returned will be paid by the customer – we do not refund return postage (unless we have supplied the incorrect item).

Please be aware that it is not uncommon for a car to have been fitted with non-standard parts at some stage, so if the new part you receive is not the same as the part on your car, do not automatically assume the new part is wrong. Let us know if you have a problem and we will try to sort it out.

BANK FEES

Customers paying by bank transfer must pay the fees charged by their own banks – we pay our own bank fees only. Where there is a short fall due to us being charged by the customer's bank, the customer will be asked to pay the difference.

POSTAGE, INSURANCE & IMPORT CHARGES

We aim to send most parcels out using a tracked service as this makes for a more secure service, tracking numbers are provided to customers on request.

For small or medium sized parcels sent within the UK we use Royal Mail's tracked 24 hour service. For larger parcels, and parcels being sent abroad, we use the courier broker World Options who give us rates with DHL, Fedex, TNT and UPS. These couriers usually deliver parcels within 5-10 days.

Orders of low value goods being sent abroad can be sent using the cheaper service offered by Royal Mail, but this is at the customer's risk. We do not offer refunds or replacements for orders which go missing when sent abroad with Royal Mail.

If a customer specifically requests a next day service this can be looked into, and we are also happy to facilitate customers who wish to arrange their own carrier.

Orders valued at £500 or over will be insured and the cost included in the shipping charge. Customers are asked to let us know if they wish to insure parcels of a lesser value.

Most orders being sent outside of the UK will incur import charges once the parcel reaches customs in the customer's country. The charges vary from country to country and we do not know how much will be charged or when. We have no control over these charges and cannot be held responsible for additional costs to customers due to their government's import policies.